

Configuration setting -- To enable this track configuration, the TS5 must be set for "alternate track configuration."

1. Temporarily connect terminal **L4** to any **C** terminal.
2. Press the **test button** for two seconds until an on-board LED starts flashing.
3. If yellow LED 2 is flashing, the TS5 is in standard configuration. If red LED 4 is flashing then "alternate track configuration is enabled (this is what's required for this configuration). To change, press the test button.
4. While red LED 4 is flashing, remove the temporary wire from L4. The TS5 will remember this configuration setting.

For TS5 rev. 3.3 and up.

When TS5 power is turned on, each LED flashes once. Then LED4 will flash three times to show that the alternate track configuration is enabled.

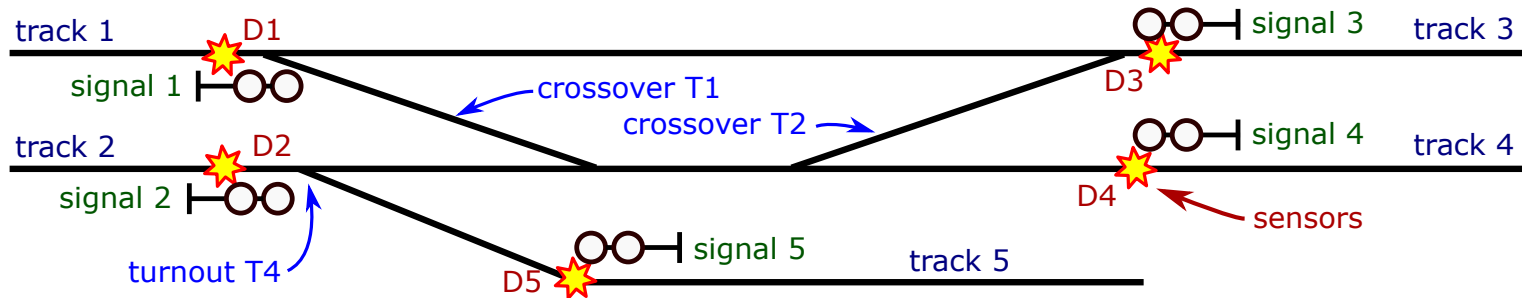

This electrical contact (switch) is linked to one of the turnouts at either end of crossover T1.

This electrical contact is linked to one of the turnouts at either end of crossover T2.

These contacts should close, connecting their T terminal to C, when their turnout is lined for the crossover (Reverse position).

They should open when their turnout is lined for the straight-through track (Normal position).

This electrical contact is linked to turnout T4.

The contact should close, connecting terminal T4 to C, when the turnout is in the diverging (Reverse) position.

It should open when the turnout is in the Normal position.

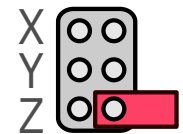
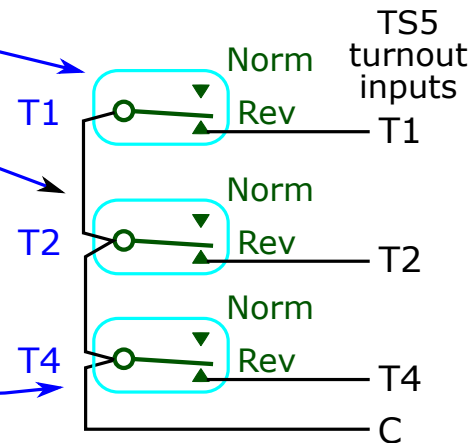

TS5 track config jumper off, or parked on one pin only

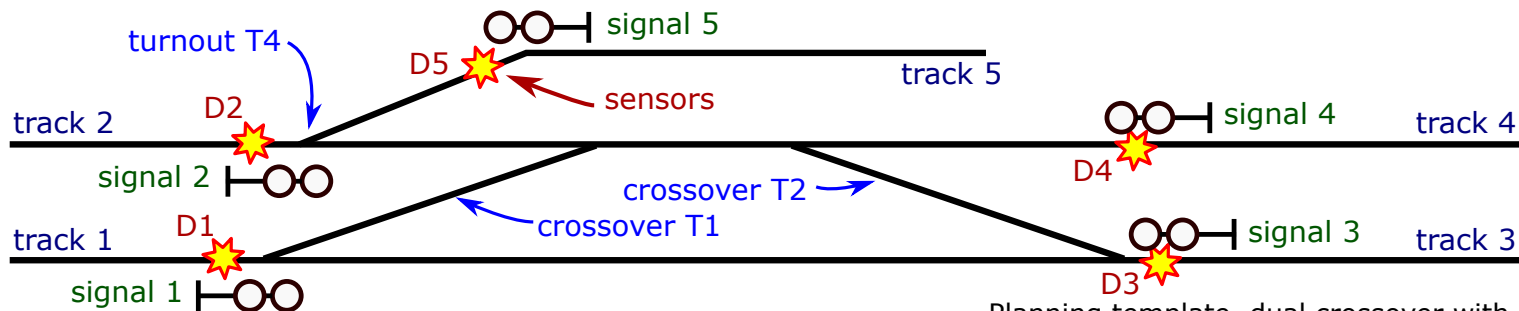

Planning template, dual crossover with narrow-side branch from track 2. Azatrax, (c) 2026