

## Installation Guide

### Azatrax Dual IR Model Train Detector for use with 3-wire (twin coil) switch machines

**What it is:** The D2X-3W 'exhibit' edition is a two-channel model train detector. It can detect two model trains at two sidings on an oval track, and alternately run the trains in opposite directions around the loop. To automatically control the track turnouts, the turnouts must be equipped with 3-wire (dual coil) switch machines.

**Three-wire switch machines** include those made by **Atlas**, **Bachmann** and **Peco**.  
To control a turnout equipped with a 2-wire switch machine, use a D2X-2W circuit.

#### Kit contents:

- ★ Circuit board
- ★ Two infrared light-emitting diodes (IR LEDs) with orange & white (2 ft length) or red & white (6 ft length) wire leads
- ★ Two IR receivers with green & yellow (2 ft length) or blue & yellow (6 ft length) wire leads
- ★ Four plastic mounting tubes. The tubes are for protection of the sensor leads and to provide mounting support. They are not essential for detector operation and may be shortened or removed entirely to best fit your situation. Use caution, do not damage the leads.
- ★ 4,700 ohm ('4.7k') resistor to change the time delay.

Additional wire may be spliced to the sensor leads if needed. Use similar twisted pair wire for total length up to 26 ft (8m).

**How it works:** Trains are detected by infrared (IR) light, invisible to the human eye. There are two sensing elements at each track location - an IR LED light source paired with an IR receiver. Green and red LEDs on the D2X show the status of the detectors and turnout points.

#### Exhibit Loop Operation

An exhibit loop layout consists of an oval of track with two passing sidings. Typically the passing sidings are hidden behind a backdrop. At one end of the layout is a model of a producer industry such as a coal mine, and at the other end is a consumer industry such as a power plant or steel mill.

Two trains operate on the layout, one with loaded cars such as hopper cars filled with coal, the other with identical empty cars. The loaded train travels from its hidden siding, around the producer site (coal mine) to the consumer site (steel mill) and then into the hidden area and its siding. The loaded train stops, then a few seconds later the empty train travels in the opposite direction from its siding, around the consumer site to the producer site, then behind the backdrop to its siding. After another pause the cycle repeats.

If space permits, another loop can show another pair of trains taking goods from the consumer site (steel mill) to another industry such as a stamping plant.

**Variable pause delay** The default pause time is four seconds. This can be made longer by connecting a resistor to terminals 'S2' and 'C'. The 4.7k resistor supplied will produce an eight second pause. Using a 10k resistor results in the maximum pause time of 25 seconds.

3k → 5 sec, 4k → 6 sec, 5k → 8 sec, 6k → 10 sec, 7k → 13 sec, 8k → 16 sec, 9k → 20 sec, 10k → 25 sec.

#### Exhibit layout wiring for AC or DCC powered trains

The D2X Exhibit Controller alternately powers the two sidings in response to the trains triggering the two sensor pairs. Make sure your trains will always start in the forward direction when power is restored to their track (lock the 'e-unit' on AC powered trains). The D2X can switch loads up to 5 amps, sufficient for most model trains.

The diagram below shows connections for an exhibit layout with AC or DCC track power.

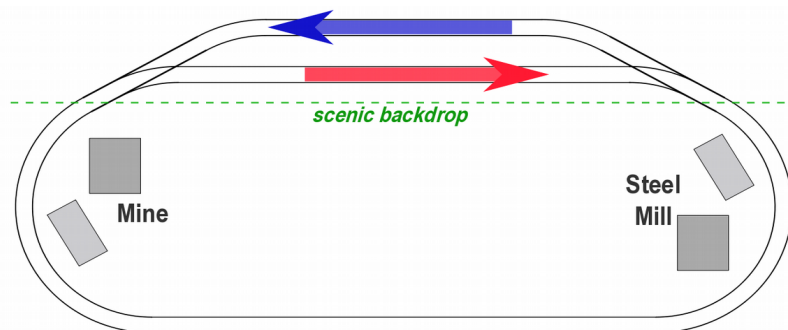
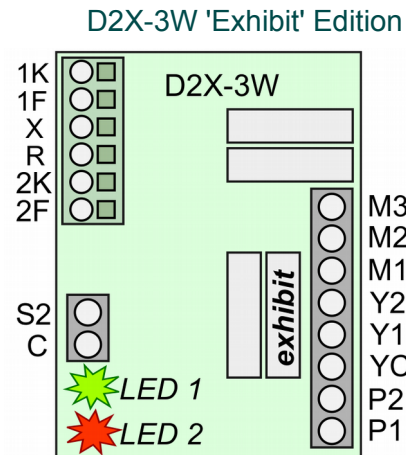

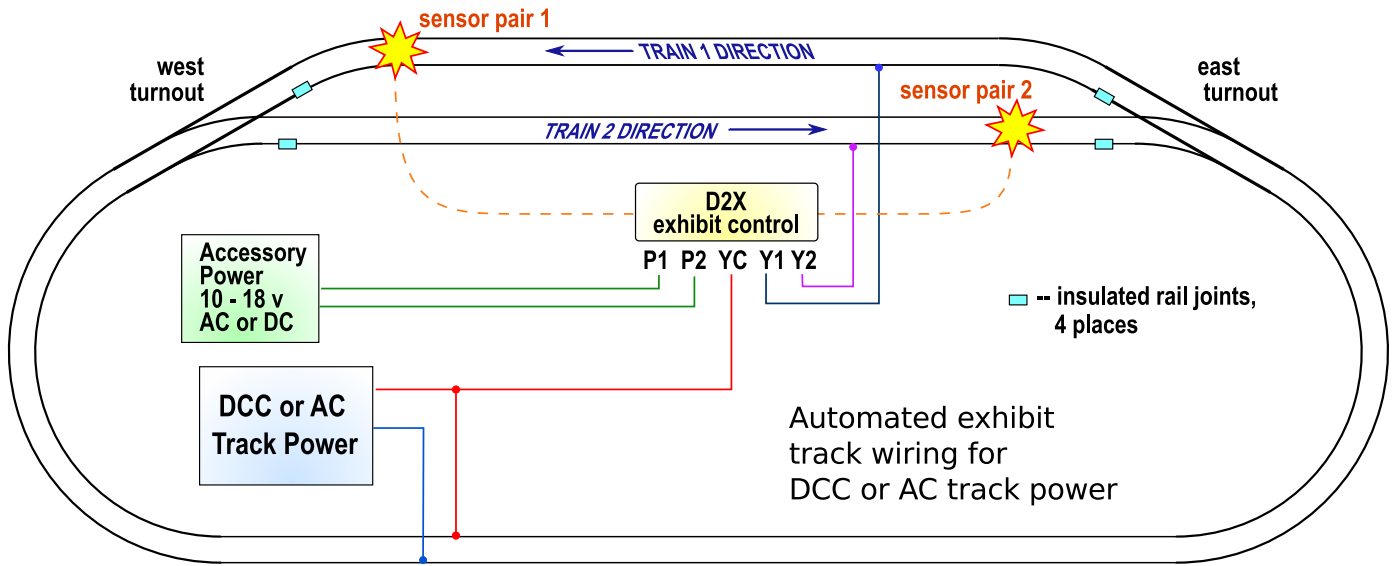
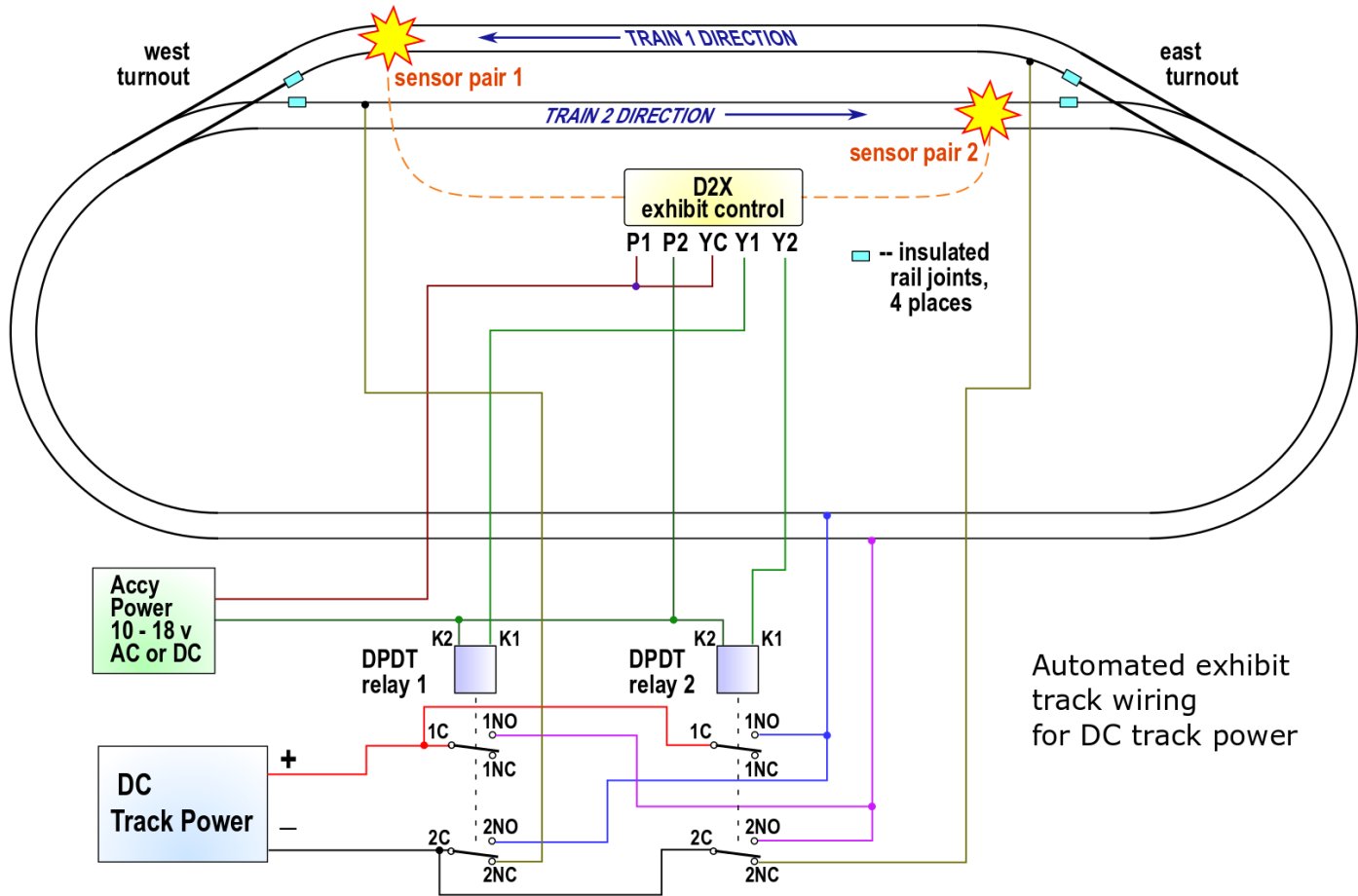

Exhibit layout wiring for DC powered trains

The direction of trains that use DC track power is determined by the +/- polarity of the track power. As shown in the diagram below, the D2X controls two relays, K1 and K2, to change the track power polarity. The relays also switch track power to the passing sidings.



**Install the sensors** Each sensor pair may be installed in one of two ways - 'Across the Track' or 'Reflective.'

**Across the Track sensing:** The IR LED is positioned horizontally on one side of the track(s), and its IR receiver is placed on the opposite side. A train is detected when it blocks the light path between the LED and receiver. The distance between the LED and its receiver can be up to 18 in. (46 cm). With careful alignment longer distances can be achieved.

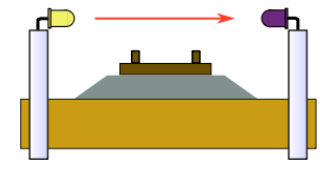

**Tip #1** - If mounting the sensors vertically as shown here, slide the plastic tubes away from the sensor then carefully bend the leads to a right angle. The leads are somewhat brittle, bending them more than two or three times may cause a break.

**Tip #2** - Locate the receiver so it faces away from bright lights or sunny windows. Use scenery or structures to conceal the sensors and shade them from room lighting.

**Reflective sensing:** Trains are detected when light from the IR LED is reflected off a train and sensed by the IR receiver. Typically the sensors are mounted in two #12 (3/16 inch or 4.8mm) holes drilled in the roadbed as shown here. Vertical installation works for S, O and larger scales as long as there is no structure above the track such as a bridge.

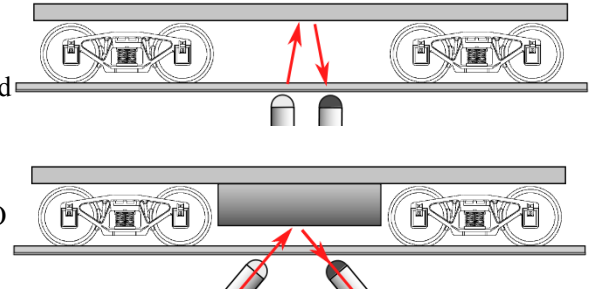

Angling the IR LED and receiver toward each other is best for N and HO scales where the trains are close to the rail head, and in places where an object above the track might otherwise cause false detections. Angle the IR LED and receiver so their centerlines intersect at the height of the bottom of your rolling stock.

**Tip #3** - You can ballast your track after sensors are installed. Cover each sensor with a bit of transparent tape. Apply ballast. When the glue has dried, use a dental pick or similar tool to remove ballast from the sensors. An opening of only 1 or 2 mm is required.

Connect the sensors to the D2X circuit board

**Connect sensor pair 1:** How you connect the IR LED and its receiver to the D2X module determines whether Detector #1 operates in 'Across the Track' or 'Reflective' mode. Strip the end of the sensor wire. Firmly push down the square button on the terminal block and insert the wire at a 45° angle. Release the button and tug on the wire to verify it is secure.

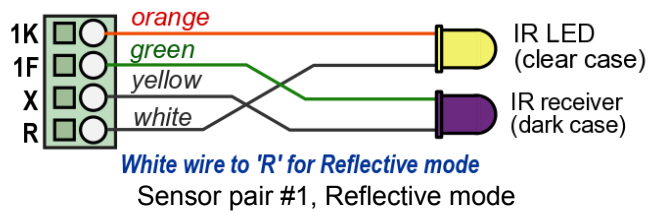
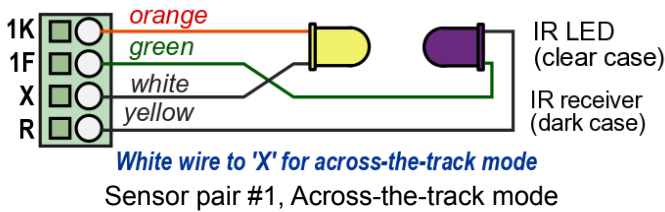

**Add connections for sensor pair 2:** Detector #2 can operate in the same mode as Detector #1, or in a different mode. Note that when both sensor pairs are wired to the D2X, there will be two white or yellow wires in terminals 'R' and 'X.' Additional wire may be spliced to the sensor leads if needed. Use similar twisted pair wire for total length up to 26 ft (8m).

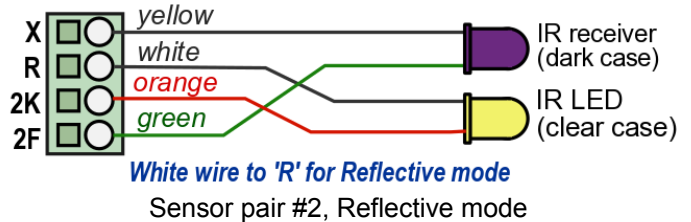
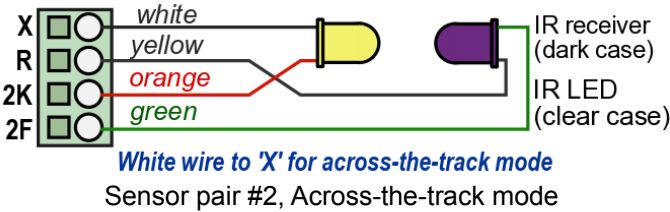

**Connect power to the D2X circuit:** 12 to 16 volts AC or DC works well with most switch machines. If one side of the power supply is connected to a layout 'common' or 'ground,' connect it to terminal 'P2'. Connect the 'hot' side to 'P1.'



When power is turned on, the D2X checks whether the IR LEDs are connected or not.

- If IR LED #1 is connected, then the green on-board LED #1 will flash twice.
- If IR LED #2 is connected, then the red on-board LED #2 will flash twice.
- If no IR LEDs are connected, the on-board LEDs will flash four times in unison.

**On-board LEDs:** A green and a red LED show the status of the sensors and the turnout position.

If the turnout points are positioned for Track 1, the green #1 LED will be on.

If the turnout points are positioned for Track 2, the red #2 LED will be on.

A flashing green #1 LED indicates that IR sensor pair #1 is detecting a train or other object.

A flashing red #2 LED indicates that IR sensor pair #2 is detecting a train or other object.



### Adjust the sensors / troubleshooting:

With no trains in either detection zone, the green and red LEDs on the D2X should not be flashing. If either LED is flashing, correct the false sensing condition.

#### **To fix false sensing for Across-the-Track mode:**

1. Verify that the sensor pair is wired correctly.
2. Make sure the IR LED and its receiver are pointed at each other, and nothing is between them.
3. Shade the receiver from bright lights, and point it away from windows or other strong light sources.
4. Change the nearby room light from incandescent to a fluorescent or LED bulb if possible.

#### **To fix false sensing for Reflective mode:**

1. Verify that the sensor pair is wired correctly.
2. Pull the IR LED and receiver a bit deeper into the roadbed.
3. Infrared light may be 'leaking' through the roadbed material from the IR LED to the receiver. Push a metal shim, such as the tip of a hobby knife blade, vertically into the roadbed between the IR LED and receiver.
4. Is there an object above the sensor, such as a bridge, or an upper layout level? Mount the IR LED and its receiver at a shallower angle, or paint the overhead object black. Or use across-the-track sensing.

Both detectors now off? Now **test for train detection**. With *track power off*, place a locomotive or car in the detection zone of IR sensor pair #1. The on-board green LED #1 should flash. If the red LED #2 also flashes, re-adjust IR sensor pair #2 for false detection (see above). If the green LED does not flash, correct sensor pair #1 for a false clear condition.

#### **To fix a false clear indication for Across-the-track mode:**

1. Verify that the sensor pair is wired correctly.
2. Adjust the sensor height so the train is fully blocking the light path from the IR LED to its receiver.

#### **To fix a false clear indication for Reflective mode:**

1. Verify that the sensor pair is wired correctly.
2. Adjust the sensors higher or lower in the roadbed.
3. A bright light source above and to the side of the track may be saturating the IR receiver. Try pulling the receiver deeper into the roadbed or create shade with scenery or a structure. Change the nearby light to a fluorescent or LED bulb.

Test with several types of rolling stock and adjust the sensors as needed.

Remove the train from IR sensor #1's detection zone, make sure the green LED stops flashing.

Place a locomotive or car in IR sensor #2's detection zone. The on-board red LED should flash. If the green LED also flashes, adjust IR sensor pair #1 for false detection (see above). If the red LED does not flash, adjust sensor pair #2 for a false clear condition (same as above for sensor pair #1).

### Connect the switch machines

Twin-coil machines are driven by one brief pulse of current.

Both switch machines connects to D2X terminals M1, M2 & M3.

**Do not connect to other buttons or circuits.**

**Do not connect 'M2' to a layout 'common' or 'ground.'**

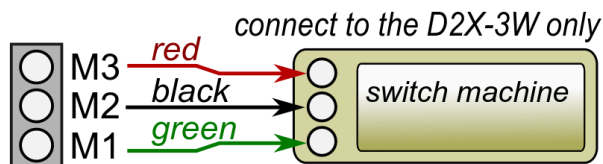

**To start**, turn track power off. Place a train on each siding with each locomotive on an IR sensor. Both red & green on-board LEDs should be flashing, one with a long 'on' time and one with short 'on' time. If the green LED has the long 'on' time, both turnouts should align to Track 1. If the red LED has the long 'on' time, both turnouts should align to Track 2.

**If either turnout aligns the wrong way, swap the M1 / M3 wires at that switch machine.**

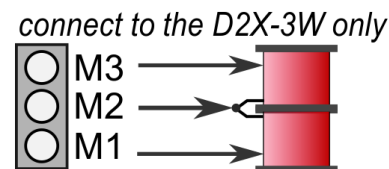

Gradually increase track power. One train should move, it should be the train on the siding that is aligned with the turnout points. If it is the other train, check the wiring to terminals 'Y1' and 'Y2' on the D2X circuit. If the train moves in the wrong direction, change the direction switch on the train power supply (power pack).