



Remote Tortoise Mount

800-6100

CONGRATULATIONS!

Your new Remote TORTOISE™ Mount (RTM) will now allow you to install the TORTOISE™ into your layout in areas where it just wouldn't fit before. Ideal for multi-level layouts with limited height between layers or any location where structural bracing might interfere with conventional TORTOISE™ mounting. The RTM is also ideal for retrofitting the TORTOISE™ to existing trackage as it is no longer necessary to drill a clearance hole up from the underside. This eliminates the risk of accidentally destroying the throwbar during the drilling process. By purchasing an extra RTM Cable and Actuator (part no. 800-6101) one TORTOISE™ can simultaneously throw two sets of points for crossovers, etc.

HOW IT WORKS

The TORTOISE™ mounts to the drive mechanism and can be located up to 18" from the turnout throwbar. A drive arm with multiple pivot holes (for adjusting the total throw) moves a slide back and forth as the TORTOISE™ runs (crawls?). A fine stainless steel wire is clamped to the slide and moves inside a small teflon™ tube, much like a sub-miniature choke cable. At the other end of the wire and tube, an actuator lever arm is swung by the moving wire. A formed piece of music wire transfers the rotary motion of the lever arm up through a brass tube extending through the layout base and roadbed to the throwbar above. Suitable for use in all scales, the Remote TORTOISE™ Mount requires only 1/2" clearance under the layout base below the throwbar and a 1/16" diameter hole through the roadbed and base. This hole will be drilled from the topside of the layout for simple installation.

The drive mechanism assembly with the TORTOISE™ mounted on it can be located above or below the layout. It may even be possible to locate the mechanism inside larger structures.

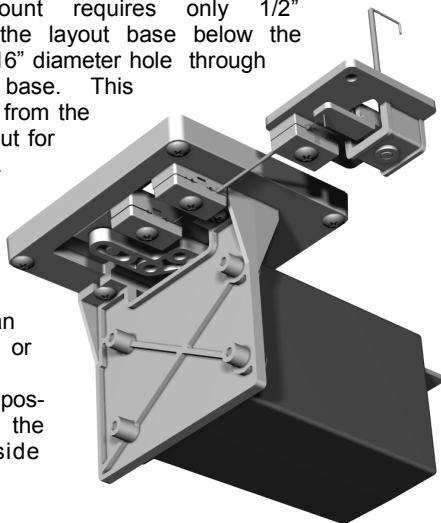

CONTENTS

Please check your kit carefully and refer to the drawings to identify all parts. You should have:

- (1) Drive Mechanism Base Plate
- (1) TORTOISE™ Mounting Plate
- (1) Drive Mechanism Arm
- (1) Slide
- (1) Slide Clamp Plate (4 Shallow Grooves)
- (1) Base Clamp Plate (4 Deep Grooves)
- (1) Actuator Mounting Plate
- (1) Actuator Clamp Plate (2 Deep Grooves)
- (1) Actuator Lever Arm
- (13) #4 x 3/8" Phillips Truss (large) Head Screws
- (4) #4 x 5/8" Phillips Pan Head Screws
- (2) #4 x 1/2" Phillips Shoulder Screw
- (1) 18" Length Stainless Steel Wire
- (1) 18" Length Teflon Tube
- (1) Guide Tube (1/16" OD Brass Tube)
- (1) .025" x 3" music wire

CAUTION: Handle the Stainless Steel Wire and Teflon Tube carefully to avoid kinking either of them. Kinks will degrade performance and may render the mechanism unusable. Replacement Wire/Tube sets are available from Circuitron for \$3.00 postpaid.

TOOLS REQUIRED

- #1 Phillips Screwdriver
- Diagonal Wire Cutters (Hardened or Heavy Duty)
- Flush Cutting Nippers
- Needle Files
- Square Jawed Needle Nose Pliers
- Abrasive Cutoff Disc in Motor Tool
- Drill with 1/16" and 3/32" drill bits.
- Hobby Knife with new (sharp) #11 Blade
- ACC Adhesive (Thin)

PREPARING THE PARTS

Remove all parts from their sprues, if necessary, and trim the gate vestiges with flush cutters. File the trimmed surface smooth on the Slide and the Actuator Lever Arm.

GETTING STARTED

Check for Clearance:

- 1) Drill a 1/16" hole down through the roadbed and sub-roadbed at one of the two locations shown.

WARNING
This hole must be drilled perpendicular to the layout surface. Use a drill guide if you have one or drill slowly while checking from all directions to ensure that your drill bit remains at right angles to the surface.

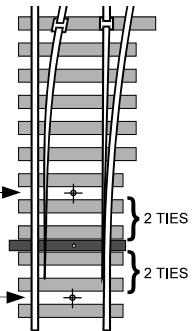

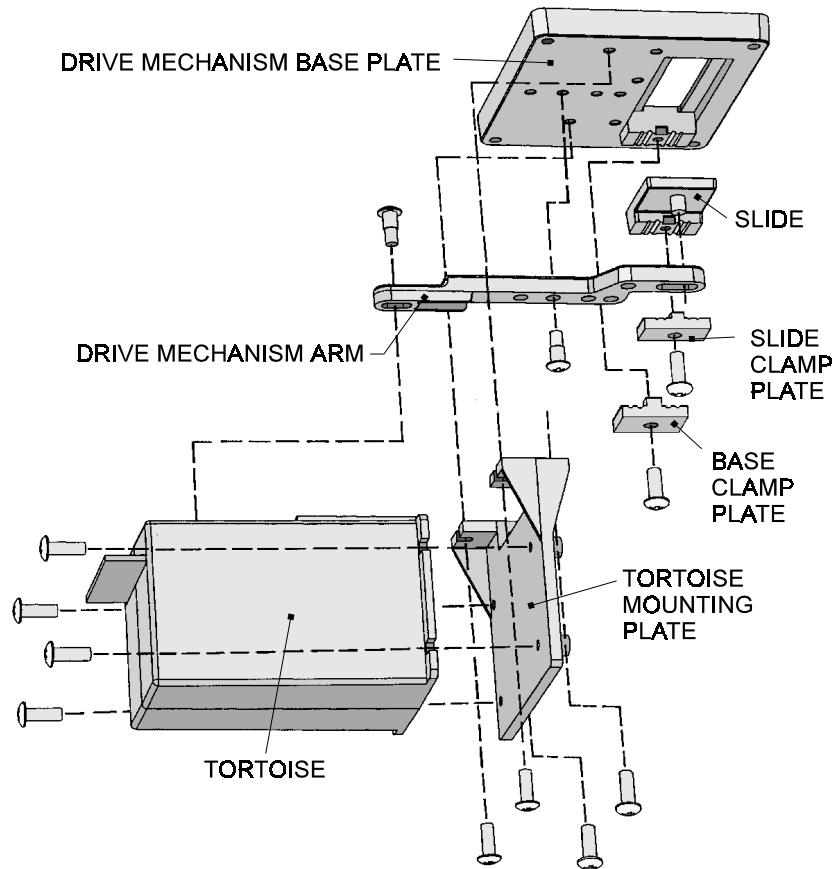

4) Drill (2) 3/32" pilot holes 3/8" deep at the two locations.

5) Using the cutoff wheel, cut off the Guide Tube below the layout so that only about 1/8" remains extended. File the end square, if necessary, and remove any burrs from the inside of the tube with the hobby knife.

6) Grasp the end of the piece of music wire with your pliers so that about 1/4" is in the jaws and make a SHARP right angle bend. Use the cutoff tool to trim this end to about 1/16". If you have good pliers, you may be able to make this short, tight bend without having to cut off any material. Your wire should now look like this:

NOW BE CAREFUL THESE NEXT 2 STEPS!

7) Lay the wire on the ties with the cutoff bent end *exactly* centered over the hole in the throwbar and the long length extending down the track over the guide tube. What's that? Your throwbar doesn't have a hole in the center? You'll have to drill one. 1/16" should do fine.

Check to make certain that there are no obstructions on the underside of the layout. There must be *at least* 1/4" clearance between the center of the hole you just drilled and the nearest obstruction. You will also need adequate clearance below the underside of the layout to drill pilot holes and drive the screws through the Actuator Mounting Plate up into the underside of the layout.

2) Insert the Guide Tube into the hole and push down until the end of the tube is flush with the tie tops. If the tube wants to drop out of the hole, fix in place with a drop of ACC.

Do Not Get Glue In the Tube!

3) Place the Actuator Mounting Plate over the Guide Tube on the underside of the layout. The tube should be extending out of the pivot hole in the center of the raised section. Center the tube in the hole and mark the two mounting hole locations with a sharp pencil. Without moving the plate, trace the outline of the cut out area in the mounting plate onto the under-side of the layout surface.

Now, remove the plate and make a mark 1/2 way between the two corners of the tracing you just made. Finally, draw a line between the center of the guide tube and extending through and 1 inch beyond the mark you just made. When you are finished, your pattern on the underside of the layout should look like this

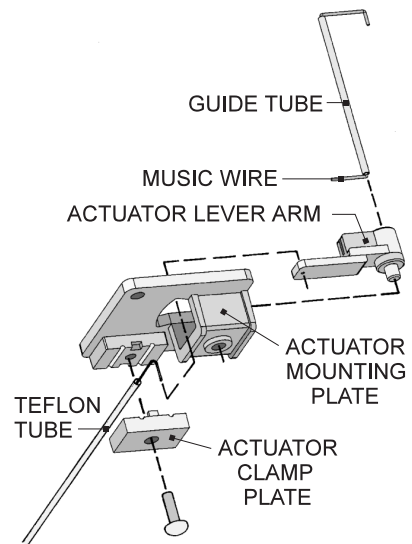
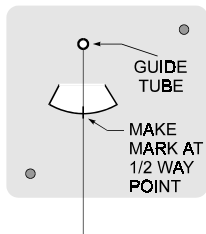

8) Using a pencil or fine tip marker, make a thin mark on the wire directly across the centerline of the guide tube hole. Grasp the wire with your pliers so that the mark you made is visible just outside the side of the jaws. Rotate the wire in the jaws so that when you make a second bend at this point, the resulting shape of the wire will be a squared "C" shape. Finally, bend the wire to a *very tight* 90 degree bend. If you did this right, your wire should lie flat on the bench and should now look like this:

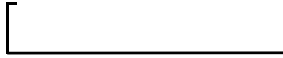

Adjust the bends with the pliers so that they are as close to 90° as you can make them and adjust the short leg so that it lies in the same plane as the longest one.

9) If you have bent the wire correctly, you can now insert the long leg of the wire into the top of the guide tube. It should drop into place with no resistance, and the short bent end should line up with and drop into the center of the throwbar hole. Manually moving the points back and forth to their extremes should move the wire easily with no binds. If you detect any resistance to smooth motion at this time, you should probably try to make another wire. If it fits in the center of the throw, but binds at the sides, enlarging the throwbar hole a little bit should help. .025" music wire is available at most hobby shops or you can order 5 pieces from us for \$3.00 postpaid.

10) Block the turnout points at their mid-position by placing toothpicks or shims between the points and the stock rails. Making sure the bent music wire is still in the throwbar hole, fasten it down to the ties with a piece of masking or duct tape to keep it from popping up.

11) From under the layout, apply mild downward force on the music wire while bending it to 90 degrees in the direction of the line you drew in Step 3. You may want to use pliers for this bend, but do not bend it so tightly against the bottom of the guide tube that it binds. Check that the wire follows the line exactly, and twist it as necessary to achieve perfect alignment. Remove the shims from the points and check the action from underneath. Rotating the wire back and forth should *smoothly* move the points above.

12) Using the cutoff wheel, trim the music wire under the layout to 1/4" long (3/16" - 5/16" will work fine).

13) Prepare the stainless steel wire by cutting 1/4" off of one end. *CAUTION: This wire is quite hard and will destroy delicate cutters. Use good quality hardened cutters or use the abrasive cutoff wheel.* Run the cut end through your fingers and make sure there are no burrs or hooks on the end.

HANG IN THERE!

IT'S GOING TO TAKE YOU FAR LESS TIME TO DO THE INSTALL THAN TO READ ALL THE INSTRUCTIONS.

LOCATING THE DRIVE MECHANISM

It is desirable to locate the Drive Mechanism with the TORTOISE™ attached as physically close to the Actuator as possible. Shorter cable lengths result in smoother action and more positive throws. Although the cable can be up to 18" long, you should shorten it if space permits. Select a location for the Drive Mechanism Base Plate near the actuator and temporarily tape or screw it in place. Tape one end of the Teflon tube in the Actuator Clamp groove and then place the tube in the Base Plate Clamp groove. The goal is to find a location for the Drive mechanism where the Teflon tube will have a minimum of bends and also the shortest overall length (short and as straight as possible is what we're after here). No bend should have less than a 2" radius (4" minimum preferred).

14) After finding the best location, make a mark on the Teflon Tube with a permanent felt tip marker at the center of the Base Plate Clamp groove. **CAUTION: HANDLE THE TEFLON TUBE WITH CARE. DO NOT KINK!** Also mark the locations of the four corner mounting holes.

COMPLETING THE ACTUATOR

15) Using the sharp hobby knife or a single edge razor blade, cut the Teflon Tube to a length 2" LONGER than the mark on the tube you made above.

16) Carefully thread the previously cut end of the stainless steel wire into one end of the cut Teflon Tube. Thread it through until it extends a few inches out the other end.

17) Make a 90 degree bend in the stainless steel wire about 1/4" in from the trimmed end.

18) Locate the small hole near the end of the Actuator Lever Arm and note that the hole is tapered. Feed the wire through the arm from the large side so that it exits the tiny opening on the other side. (If it doesn't want to go through, it may be necessary to enlarge the hole slightly with a #75 - 80 drill bit in a pin vise.) Bend the wire into a "Z" shape, capturing it in the arm.

19) Feed the large end of the arm through the large opening in the Actuator Mounting Plate. Rotate the arm to seat the pin into the molded hole in the plate. The Teflon Tube should line up with the molded groove in the Actuator Mounting Plate clamp block.

20) Lay the Teflon Tube in the clamp block groove so that the end of the tube is flush with the inside edge of the clamp block. Place the Clamp Plate on top and making sure that the tube is fully seated in the groove, press it down in place. Use a # 4 x 3/8" Phillips Truss Head Screw to clamp the plate tightly to the block.

21) Put the Actuator Plate/Lever Arm assembly in position under your turnout. The hole in the Lever Arm should fit cleanly over the projecting stub of the guide tube and the molded groove in the Lever Arm should engage the piece of music wire. If everything seems to fit smoothly together, attach the plate to the layout with 2 Truss Head Screws in the previously drilled pilot holes. Hold the Teflon Tube in one hand and move the stainless wire in and out with the other. The points should move smoothly and without binds.

ASSEMBLING THE DRIVE MECHANISM

The Drive Mechanism can be set for 5 different total travel lengths. The pivot holes are numbered 1 through 5 with number 1 being closest to the Slide.

1st Pivot Hole	.125" Total Travel
2nd Pivot Hole	.150" Total Travel
3rd Pivot Hole	.275" Total Travel
4th Pivot Hole	.490" Total Travel
5th Pivot Hole	.675" Total Travel

We recommend providing a small amount of over-travel to develop some spring tension on the points. Use of the 4th pivot hole as shown in the exploded diagram is recommended for this application. In certain applications and scales, use of the 3rd pivot hole will reduce over-travel and thereby reduce the tension on the points.

22) Drill 4 pilot holes 1/2" deep at the locations you marked in Step 14. Use a 3/32" drill bit.

23) Place the Slide in the recessed area of the Base Plate so that the raised Clamp Block on the Slide is next to the raised Clamp Block on the Base Plate.

24) Place the end of the Drive Mechanism Arm with the longest slot over the molded pin on the Slide so that the 5 Pivot Holes in the Arm line up with the molded holes in the Base Plate.

25) Place one of the # 4 Shoulder Screws in the 4th hole and screw it into the base. Tighten gently, then back out 1/8 turn. The Arm (and Slide) should move easily back & forth.

26) Partially thread 2 Truss Head Screws into the holes indicated.

27) Slip the mounting flanges on the TORTOISE™ Mounting Plate under the two screw heads. The smooth side of the Plate faces AWAY from the Slide.

28) Screw 2 more Truss Head Screws through the remaining two slots in the Mounting Plate into the Base and tighten all four screws securely.

29) Attach the TORTOISE™ to the smooth side of the Mounting Plate with 4 additional Truss Head Screws.

30) Align the Drive Mechanism Arm with the TORTOISE™ arm projecting through the case. Insert the final # 4 Shoulder Screw into the molded hole in the TORTOISE™ arm. *Do Not Over-Tighten!*

31) Test the operation by applying power (9-12 vDC) to the #1 and #8 terminals on the TORTOISE™ circuit board. Then reverse your connections to make the TORTOISE™ run the other way. There should be no binds and the Slide should move smoothly back and forth. Remove power.

CONNECTING THE CABLE

32) Once again, block your turnout points at their mid-position using toothpicks or shim stock between the points and the stock rails.

33) Examine the Slide Clamp Plate and the Base Clamp Plate. Notice that the Slide Clamp Plate has very fine grooves in its bottom surface whereas the Base Clamp Plates grooves are much deeper.

CAUTION: These two parts are not interchangeable and are keyed to fit only the proper location. **FORCING** the parts in the wrong location will likely damage them and void your warranty.

34) GENTLY move the TORTOISE™ arm to the very center of its travel. *Be careful!* Applying too much force too fast may damage the gears.

35) Lay the Teflon Tube in one of the two slots in the raised Base Clamp Block closest to the center screw hole. The Stainless Steel Wire should be laying across the corresponding slot in the Slide and extending out over the Drive Mechanism Arm.

36) Place the Base Clamp Plate over the Teflon Tube and being very careful to keep the tube straight in the slots, press the Clamp Plate down. Insert a Truss Head Screw through the Clamp Plate and into the Base. The end of the tube should be *barely* visible projecting toward the Slide. Tighten the screw.

37) Follow the same procedure with the Wire in the Slide, making certain that it is aligned with the proper fine groove before fully tightening the screw.

38) Cut off the excess wire projecting past the Slide Clamp with your diagonal cutters or cutoff wheel.

39) Test the operation under power and check that the points are at the mid-point of their throw when the TORTOISE™ is at the mid-point of its throw. If the throw appears off-center, you can adjust it by loosening the Base Clamp Plate slightly and moving the Teflon Tube one way or the other a small amount. Mount the assembly with four # 4 x 5/8 Phillips Pan Head Screws

40) [OPTIONAL] Once you are satisfied with the operation, you can place a *TINY* drop of ACC adhesive where the Teflon Tube enters the Base Clamp. Do the same for the Actuator Clamp. **DO NOT GET ANY GLUE NEAR THE ENDS OF THE TEFLON TUBE.** The adhesive will wick into the clamp and prevent the tube from ever moving, but can be removed by disassembling.

TO POWER 2 SETS OF POINTS FROM ONE TORTOISE™

The Remote TORTOISE™ Mount can accommodate a second Cable and Actuator (Part Number 800-6101). All instructions are the same but use the second set of slots closest to the screw hole on the Base and Slide Clamps.

DO NOT USE ANY LUBRICANTS ON THIS MECHANISM

CIRCUITRON, INC.

211 RocBaar Drive

Romeoville, IL 60446-1163

(815) 886-9010 FAX: (815) 886-9076

