

This electrical contact (switch) is linked to one of the turnouts at either end of crossover T1.

This electrical contact is linked to one of the turnouts at either end of crossover T2.

These contacts should close, connecting their T terminal to C, when their turnout is lined for the crossover (Reverse position).

They should open when their turnout is lined for the straight-through track (Normal position).

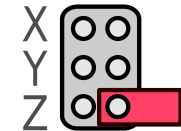
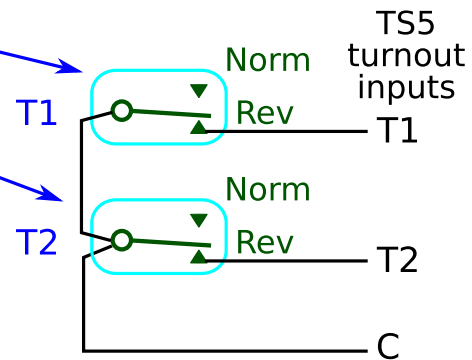

TS5 track config jumper off, or parked on one pin only

