

**What it is:** The D2T-3W-SS is a two-channel model train detector using advanced infrared ('IR') technology. It automates a model railroad track switch to operate like a spring switch on a real railroad, if the model switch is actuated with a 3-wire switch machine.

Three-wire (or 'twin-coil') switch machines include those made by **Atlas, Bachmann, Peco, Kemtron** and others.

*To control a switch equipped with a 2-wire switch machine use a D2T-2W-SS circuit.*

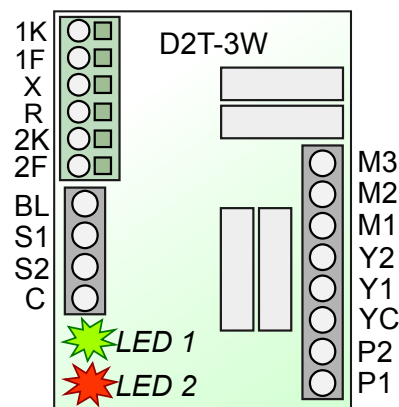

**Kit contents:**

- ★ Circuit board
- ★ Two infrared light-emitting diodes (IR LEDs) with orange & white wire leads
- ★ Two IR receivers with green & yellow wire leads
- ★ Four plastic mounting tubes. The tubes are for protection of the sensor leads and to provide mounting support. They are not essential for detector operation and may be shortened or removed entirely to best fit your situation. Use caution, do not damage the leads.

**Why use a spring switch?** A spring switch allows a train to enter the main line from a branch track without human intervention. In remote areas it saves the train crew from having to stop and reset the switch after entering the main line and walking back to the locomotive, and it eliminates the risk of someone forgetting to reset the switch.

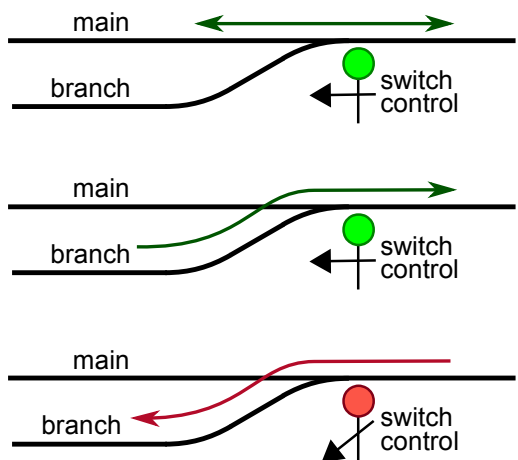

**How a spring switch works:** The switch control (usually a manual control device) is normally set with the switch points lined for the main track. Trains move in either direction through the switch points on the main track.

A spring in the control device holds the point rails in position. When a train on the branch track enters the switch and the points are lined for the main track, the weight of the wheel flanges pushes against the point rails. The spring allows the point rails to move to the branch position and the train safely enters the main track. The spring immediately re-lines the points to the main track when the train wheels have passed.

When a train is to exit the main line and enter the branch track or yard, the point rails must be manually lined for the branch track. After the end of the train clears the switch, the points are manually re-lined for the main track, and in remote areas the crew member must walk back to the locomotive.

**Why is a simulator circuit needed for model railroads?** Why not simply use a spring like the real railroads? Because model trains cars, particularly the smaller scales, are not heavy enough to overcome the combined force of a spring and the friction of the point rails. If the lightweight cars cannot move the point rails, the cars will derail.

**How the D2T spring switch simulator works:** Normally the switch points are lined with the main track, the "green" position, just like the real spring switch. Trains travel on the main track in either direction, nothing happens when trains cross sensor #1.

When a train moves from the branch track toward the main track it triggers sensor #2. The D2T simulator circuit automatically lines the switch with the branch track.

Two seconds after the end of the train clears sensor #1, the D2T re-lines the switch with the main track. The two second delay is a safeguard against intermittent sensing of the train.

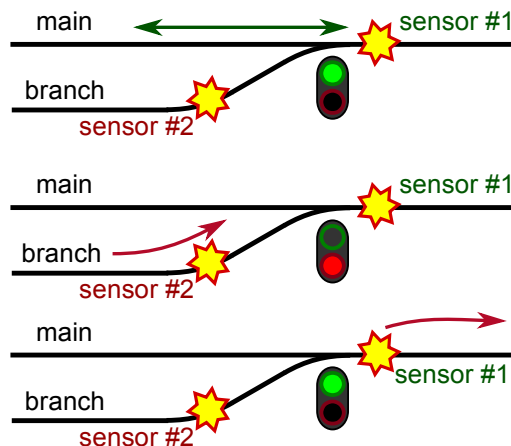

To exit the main line into the branch track: Before the train reaches the switch, use a push button or toggle to line the switch to the branch track. (Push button and toggle connections are shown below.)

**After the switch has been manually lined with the branch track, automatic operation is disabled.**

The switch remains lined with the branch track.

**To restart automatic operation** use the push button or toggle to line the switch with the main track..

Push button or toggle switch connection: To have manual operation of the switch, connect a toggle switch or two push buttons as shown here.

**Use push buttons that are “momentary, normally open.”**

Pressing the button connected to 'S1' will line the point rails for the main track, pressing the button connected to 'S2' will line the point rails to the branch track.

A toggle switch may be used in place of the push buttons. Either a standard 2-position toggle switch or a momentary center-off toggle may be used.

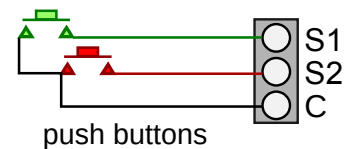
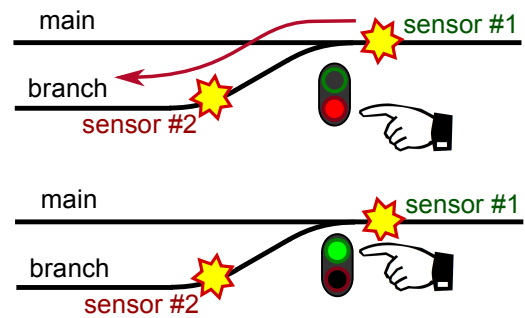

push buttons

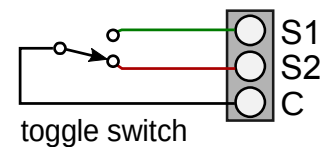

toggle switch

### Install the sensors

Trains are detected by infrared (IR) light, invisible to the human eye. There are two sensing elements at each sensor location - an IR LED light source paired with an IR receiver.

The switch can be controlled manually by connecting push buttons to the D2T.

Green and red LEDs on the D2T show the status of the detectors and the position of the point rails.

Each sensor pair may be installed in one of two ways - 'Across the Track' or 'Reflective.' Place sensor #1 on the main track, ahead of the point rails. Place sensor #2 on the branch track. Sensor leads may be extended up to 26 feet (8 meters) with similar twisted pair wire. Wire from telephone or 'Cat 5' computer cable works well.

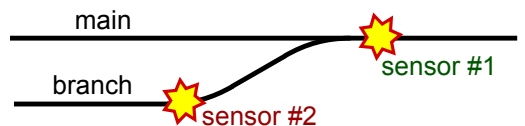

**Across the Track sensing:** The IR LED is positioned horizontally on one side of the track(s), and its IR receiver is placed on the opposite side. A train is detected when it blocks the light path between the LED and receiver. The distance between the LED and its receiver can be up to 18 in. (46 cm). With careful alignment longer distances can be achieved.

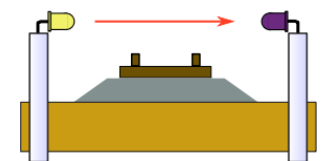

**Tip #1** - If mounting the sensors vertically as shown here, slide the plastic tubes away from the sensor then carefully bend the leads to a right angle. The leads are somewhat brittle, bending them more than two or three times may cause a break.

**Tip #2** - Locate the receiver so it faces away from bright lights or sunny windows. Sensors can be concealed by scenery or structures.

**Always turn off power before making or changing connections !**

**Reflective sensing:** Trains are detected when light from the IR LED is reflected off a train and sensed by the IR receiver. Typically the sensors are mounted in two #12 (3/16 inch or 4.8mm) holes drilled in the roadbed as shown here. Vertical installation works for S, O and larger scales as long as there is no structure above the track such as a bridge.

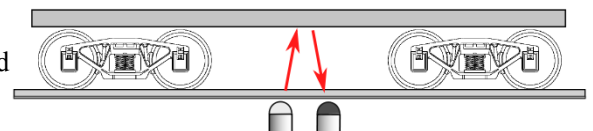

Angling the IR LED and receiver toward each other is best for N and HO scale where trains are close to the rail head, and in places where an object above the track might otherwise cause false detections. Angle the IR LED and its receiver so their centerlines intersect at the height of the bottom of your rolling stock.

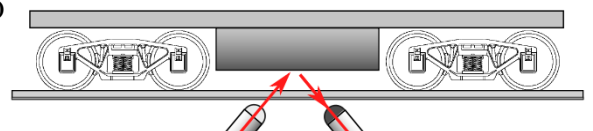

**Tip #3** - You can ballast your track after sensors are installed. Cover each sensor with a bit of transparent tape. Apply ballast. When the glue has dried, use a dental pick or similar tool to remove ballast from the sensors. An opening of only 1 or 2 mm is required.

Connect the sensors to the D2T circuit board

**Connect sensor pair 1:** How you connect the IR LED and its receiver to the D2T module determines whether Detector #1 operates in 'Across the Track' or 'Reflective' mode. Strip the end of the sensor wire. Firmly push down the square button on the terminal block and insert the wire at a 45° angle. Release the button and tug on the wire to verify it is secure.

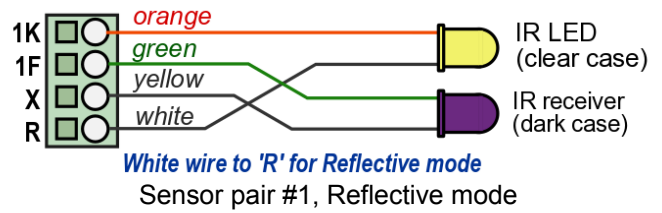
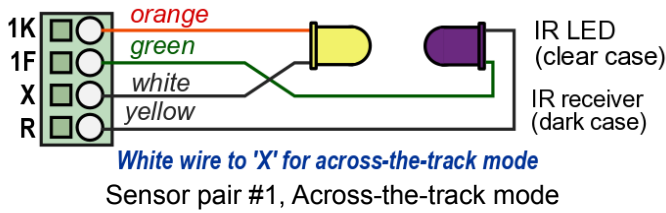

**Add connections for sensor pair 2:** Detector #2 can operate in the same mode as Detector #1, or in a different mode. Note that when both sensor pairs are wired to the D2T, there will be two white or yellow wires in terminals 'R' and 'X.' Additional wire may be spliced to the sensor leads if needed. Use similar twisted pair wire for total length up to 25 ft (7.5m).

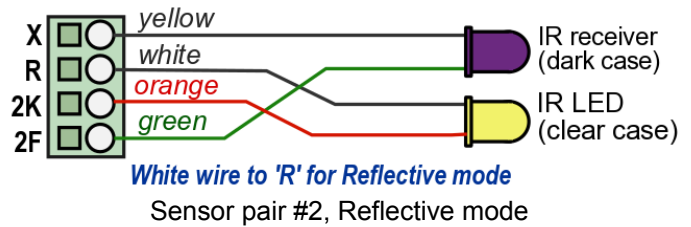
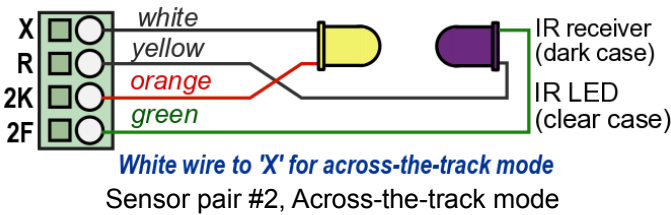

Connect power to the D2T-3W circuit: 12 to 16 volts AC or DC works well with most switch machines. If one side of the power supply is connected to a layout 'common' or 'ground,' connect it to terminal 'P2'. Connect the 'hot' side to 'P1.'

When power is turned on, the D2T checks whether the IR LEDs are connected or not.

- If IR LED #1 is connected, then the green on-board LED #1 will flash three times.
- If IR LED #2 is connected, then the red on-board LED #2 will flash three times.
- If no IR LEDs are connected, the on-board LEDs will flash four times in unison.



On-board LEDs: A green and a red LED show the status of the sensors and the points position.

If the point rails are positioned for the main track, the green #1 LED will be on.

If the point rails are positioned for the branch track, the red #2 LED will be on.

A flashing green #1 LED indicates that IR sensor pair #1 is detecting a train or other object.

A flashing red #2 LED indicates that IR sensor pair #2 is detecting a train or other object.



Adjust the sensors / troubleshooting:

With no trains in either detection zone, the green and red LEDs on the D2T should not be flashing. If either LED is flashing, correct the false sensing condition.

**To fix false sensing for Across-the-Track mode:**

1. Verify that the sensor pair is wired correctly.
2. Make sure the IR LED and its receiver are pointed at each other, and nothing is between them.
3. Shade the receiver from bright lights, and point it away from windows or other strong light sources.
4. Change the nearby room light from incandescent to a fluorescent or LED bulb if possible.

**To fix false sensing for Reflective mode:**

1. Verify that the sensor pair is wired correctly.
2. Pull the IR LED and receiver a bit deeper into the roadbed.
3. Infrared light may be 'leaking' through the roadbed material from the IR LED to the receiver. Push a metal shim, such as the tip of a hobby knife blade, vertically into the roadbed between the IR LED and receiver.
4. Is there an object above the sensor, such as a bridge, or an upper layout level? Mount the IR LED and its receiver at a shallower angle, or paint the overhead object black. Or use across-the-track sensing.

Both detectors now off? Good, now **test for train detection**. Place a locomotive or car in the detection zone of IR sensor pair #1. The on-board green LED #1 should flash. If the red LED #2 also flashes, re-adjust IR sensor pair #2 for false detection (see above). If the green LED does not flash, correct sensor pair #1 for a false clear condition.

**To fix a false clear indication for Across-the-track mode:**

1. Verify that the sensor pair is wired correctly.
2. Adjust the sensor height so the train is fully blocking the light path from the IR LED to its receiver.

**To fix a false clear indication for Reflective mode:**

1. Verify that the sensor pair is wired correctly.
2. Adjust the sensors higher or lower in the roadbed.
3. A bright light source above and to the side of the track may be saturating the IR receiver. Try pulling the receiver deeper into the roadbed or create shade with scenery or a structure. Change the nearby light to a fluorescent or LED bulb.

Test with several types of rolling stock and adjust the sensors as needed.

Remove the train from IR sensor #1's detection zone, make sure the green LED stops flashing.

Place a train in IR sensor #2's detection zone. The on-board red LED should flash. If the green LED also flashes, adjust IR sensor pair #1 for false detection (see above). If the red LED does not flash, adjust sensor pair #2 for a false clear condition (same as above for sensor pair #1).

Connect the switch machine

Twin-coil machines are driven by one brief pulse of current.

The switch machine connects to D2T-3W terminals M1, M2 & M3.

If the points move in the wrong direction, swap the wires at M1 & M3.

**Do not connect to other buttons or circuits.  
Do not connect 'M2' to a layout 'common' or 'ground.'**

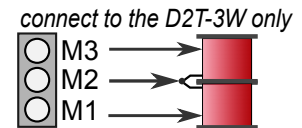
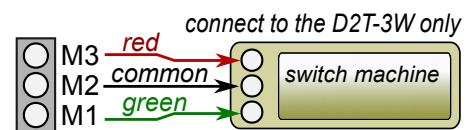

On-board relay contacts: A single pole (SPST) relay is connected to terminals Y1 and YC, and a second SPST relay is connected to terminals Y2 and YC.

Y1 connects to YC when the switch is lined to the main track.

Y2 connects to YC when the switch is line to the branch track. The relay contacts are rated 3 amps, 30 volts max.

